

DIR[®]

Mar Egeo III

8230-3G

INSTRUCTION MANUAL

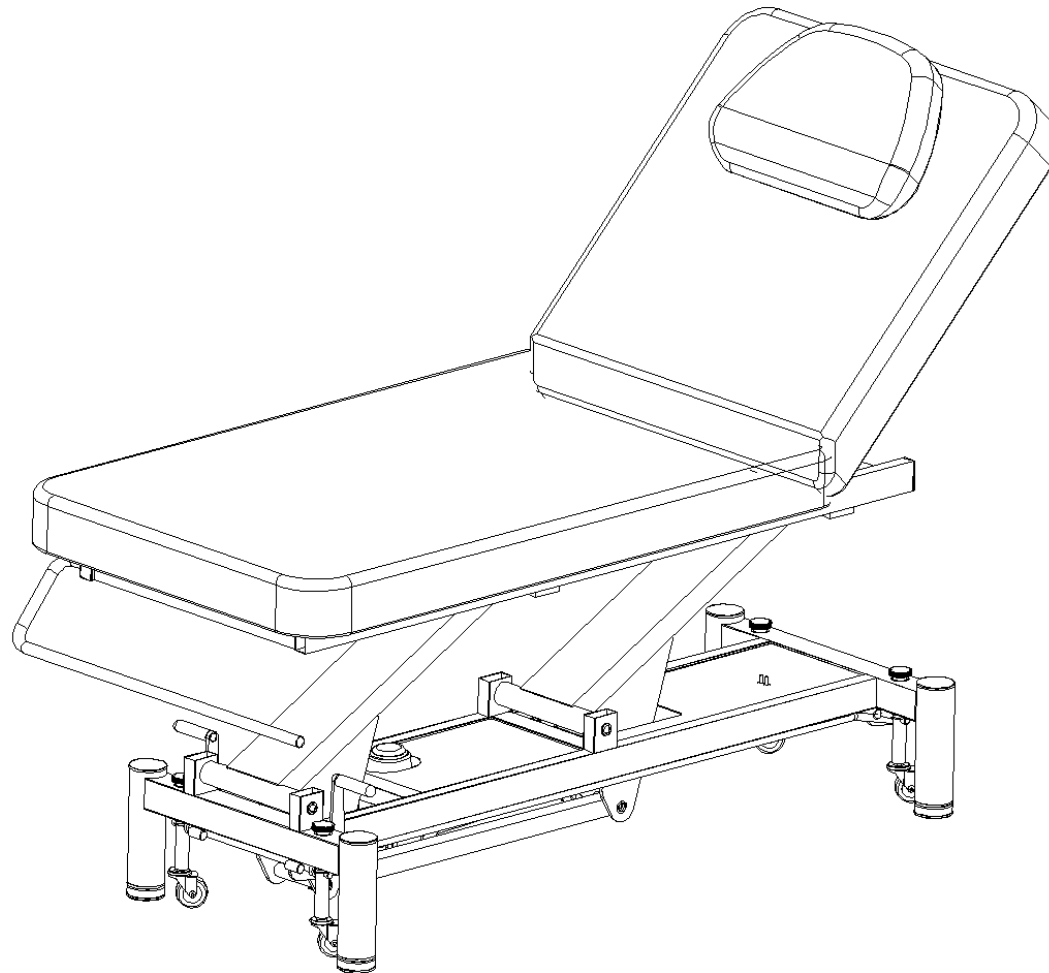

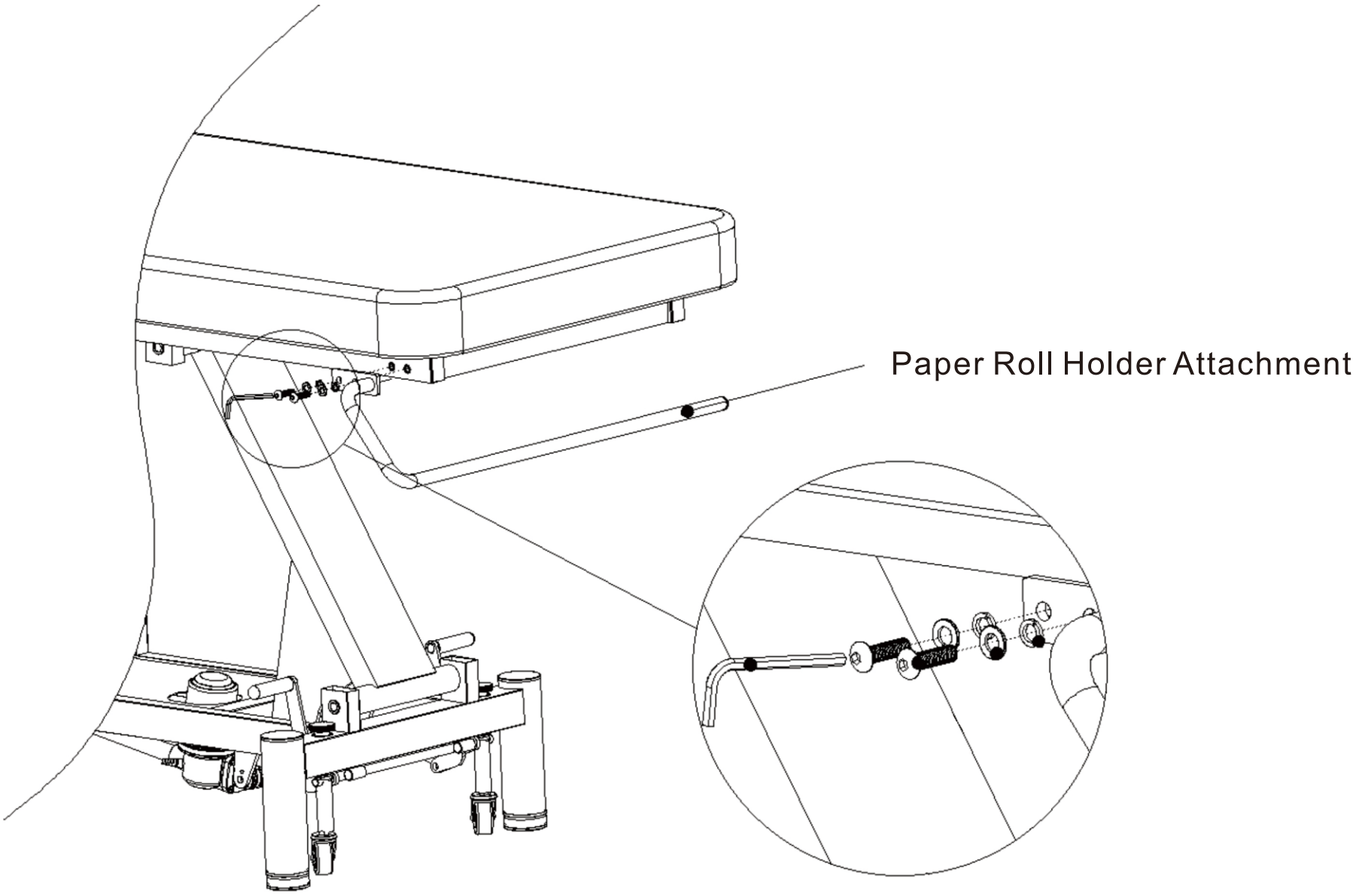

Paper Roll Holder Attachment

Align Paper Roll Holder onto frame, secure it in place with provided Screws, Washers, Lock Washer and Hex Key.

Roller Wheels Engagement

Step on Foot Pedal to engage Roller Wheels ,
rubber casters allow easy & smooth maneuvering.
Pull up Foot Pedal to disengage rolling function,
unit will stabilize in position.

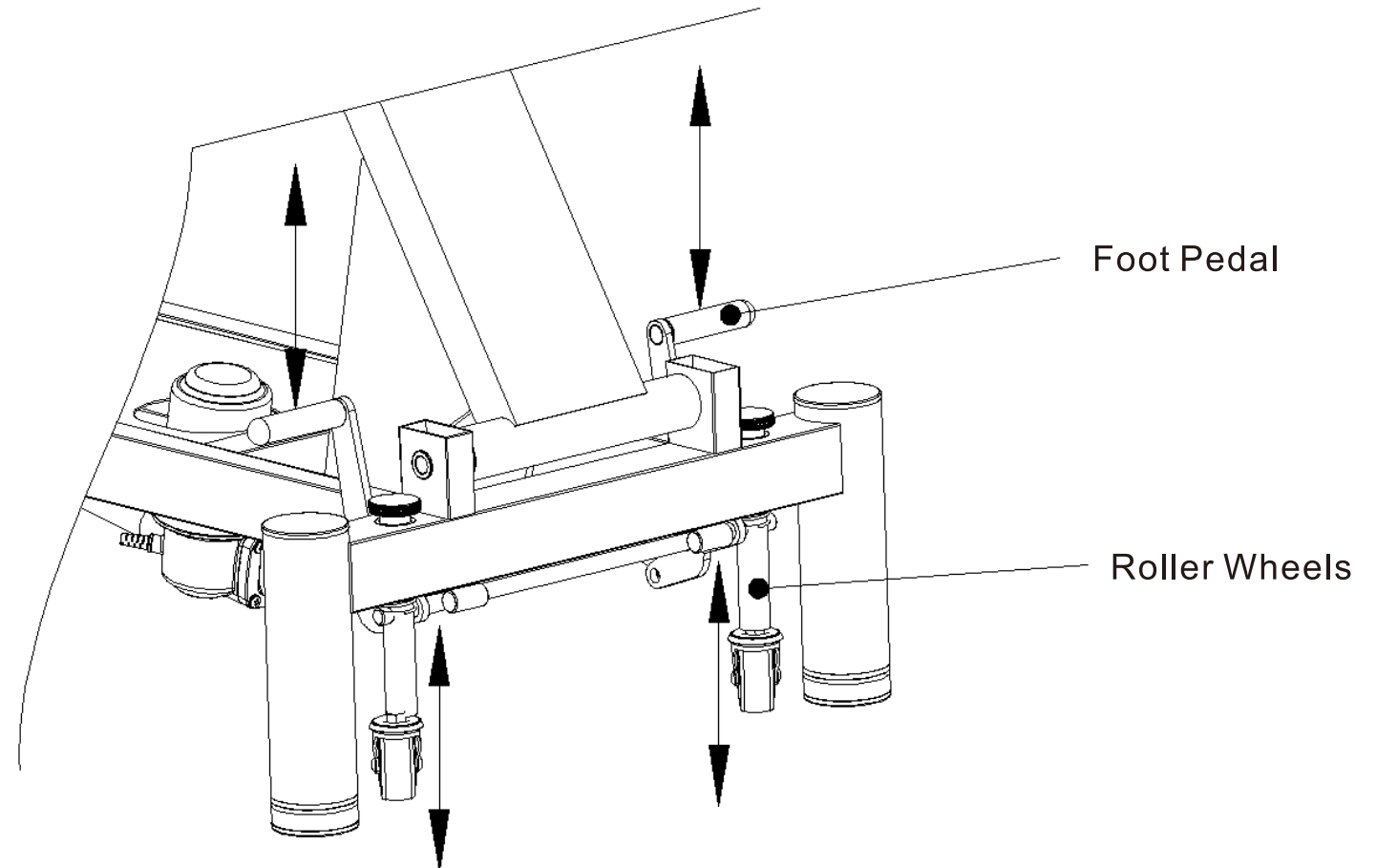

Adjustable Foot Leveller

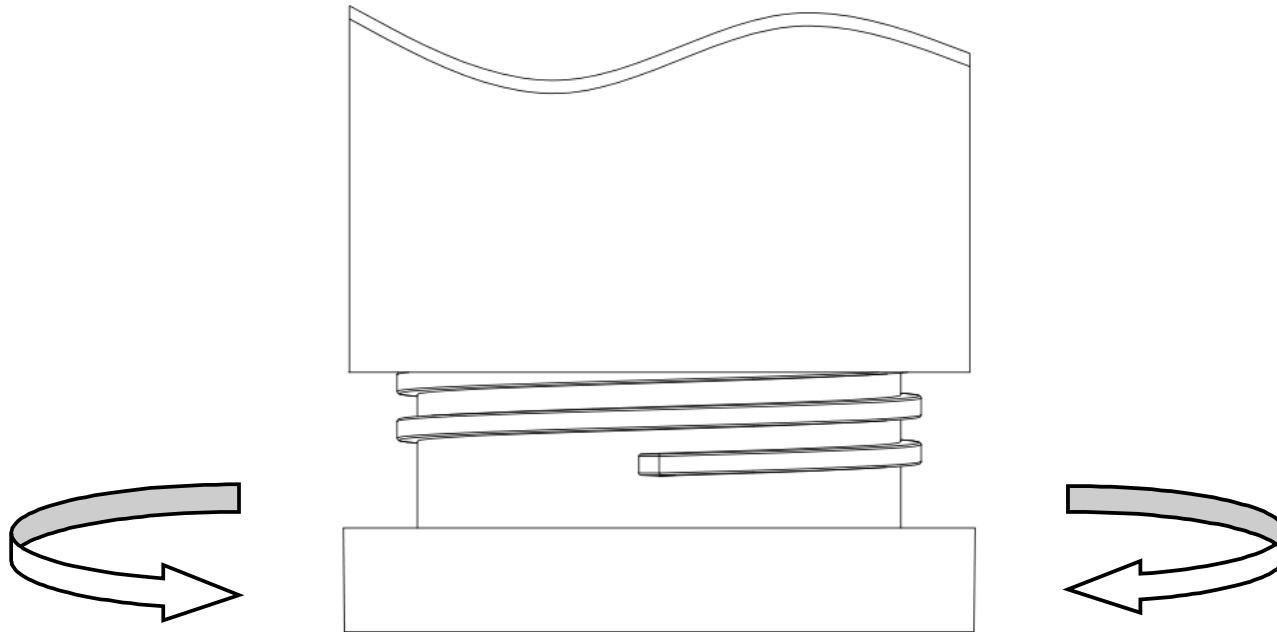

Conveniently adjust legs to stabilize the bed on uneven surfaces.

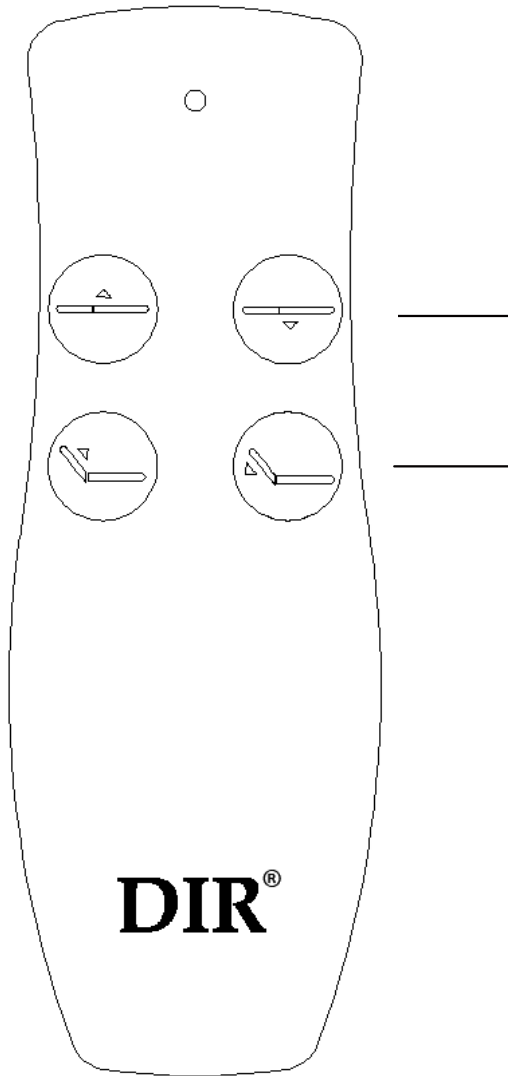



Hand Remote Function

Press  or  to raise & lower the height of the bed.

Press  or  to adjust the recline position of the backrest.

Foot Remote Function

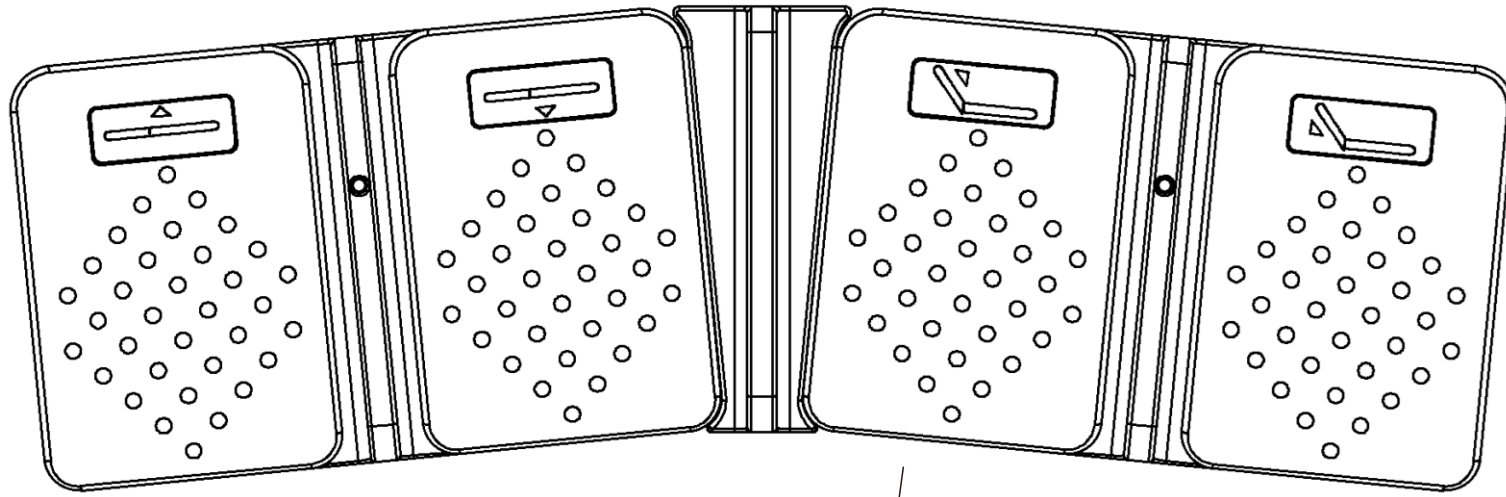

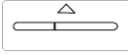
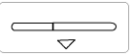
Press  or 
to raise & lower the height of the bed.

Press  or 
to adjust the recline position of the backrest.

Troubleshooting

Issue	Cause	Solution
Hand and foot remotes are not operational	Power supply disconnected	Check and confirm the unit is connected to working outlet.
	Adjustments at their peak position	Press the opposite direction function.
	Hand/Foot remote not connected to control box	Check and confirm Hand/Foot Remotes ports are connected
Abnormal sound and/or noise	Failed Actuators	Remove and replace bad actuator
	Moving Joints and Actuators short of lubricating oil/fluid	Add lubricating oil/fluid to all moving parts and joints.
Power Indicator off	Fuse has burnt out	Remove and replace bad fuse
	Power supply not connected	Check and confirm the unit is connected to working outlet

Product care



Brush away excess hair

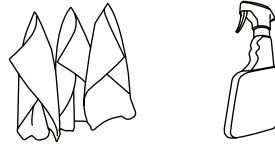

Clean surface with damp cloth or use simple soap & water solution.

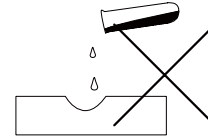

Avoid using corrosive cleaning agents such as bleaches.

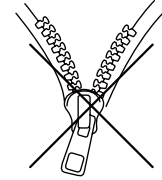

Do not remove upholstery for cleaning

Warranty

The warranty period is one year. DIR warrants to you, the original buyer, that goods shall be free of defects in material and/or workmanship attributable to manufacture for one year from date of receipt of product. Damage resulting from improper handling after merchandise is received, or from exposure to weather or extreme atmospheric conditions is not covered by the warranty. For any other information please contact our support team:

DIR Birmingham

66 Rea Street South
Birmingham
B5 6LB

Email: sales@dirstore.co.uk
Phone: +44 (0) 121 6434777

DIR London

Unit 1 River Road Business Park,
33 River Road, Barking,
Greater London, 1G11 0DA

Email: sales@dirstore.co.uk
Phone: +44 (0) 20 8591 9310

DIR New York

575 Underhill Blvd Suite #170
Syosset, NY 11791, USA

Email: sales@dirsalonfurniture.com
Phone: +1 (718) 628 6668
+1 (800) 728 2008
Fax: +1 (855) 628 5168